



POLITECNICO DI TORINO

LABORATORIO MARMO

April, 11 2007

REPORT LM/KP_02/07in

REPORT ON DETERMINATION OF PHYSICAL AND MECHANICAL PROPERTIES ON A SAMPLE OF A NATURAL STONE NAMED KIRMENJAK

The Scientific Coordinator:
(Dott. Paola Marini)



DETERMINATION OF PHYSICAL AND MECHANICAL PROPERTIES ON A SAMPLE OF A NATURAL STONE NAMED KIRMENJAK

Requested by: KAMEN d.d. PAZIN, 52000 PAZIN, Trg Slobode 2
HRVATSKA

Tested stone: (denomination in accordance with EN 12440):

Traditional name: KIRMENJAK

Petrographic name: limestone

Region of extraction: Kirmenjok (Vrsar, Istria, Republic of Croatia)

The following tests have been requested, also according to EN 1341, 1342 and 1343, 1469, 12057, 12058, CE marking standards for slabs, kerbs and setts of natural stone for external paving and for slabs for cladding, modular tiles, slabs for floors and stairs:

- petrographic examination, according to EN 12407;
- real and apparent density, open and total porosity, according to EN 1936;
- water absorption, according to EN 13755;
- flexural strength under concentrated load according to EN 12372;
- freeze-thaw resistance, according to EN 12371 and EN 12372;
- compressive strength, according to EN 1926;
- freeze-thaw resistance, according to EN 12371 and EN 1926;
- rupture energy according to EN 14158;
- abrasion resistance, according to EN 1341, Annex C and EN 1342, Annex B;
- slip resistance, according to EN 1341 Annex D and EN 1342, Annex C and to to EN 14231 for the following surface finishes:
 - bush-hammered
 - flamed;
- modulus of elasticity according to EN 14580;
- KNOOP microhardness according to EN 14205;
- linear thermal expansion coefficient according to EN 14581;
- breaking load at dowel hole, according to EN 13364;
- resistance to salt crystallisation according to EN 12370.



TEST RESULTS

PETROGRAPHIC EXAMINATION

Test method:

The test has been performed according to EN 12407 – 2007 Natural stone test methods – Petrographic examination.

Macroscopic description:

The hand specimen appears very fine grained and has an ivory colour. It is characterized by the presence of stylolites and re-crystallized fractures, no porosity is present.

Microscopic description:

In thin section the rock appears almost completely made up by calcite, moderately sorted and without pores. Some veins of sparitic calcite (re-crystallized fractures) are present.

The constituents are:

micritic matrix (90%);

Fragments of fossils of bryozoa and algae whose dimensions vary from 1 mm to 3 mm (10%).

The rock is a limestone (fossiliferous micrite).



APPARENT DENSITY, REAL DENSITY, OPEN POROSITY AND TOTAL POROSITY;

Test method:

The apparent density, real density and the total porosity have been determined according to EN 1936- 2006 Natural stone test methods - Determination of real density and apparent density and of total and open porosity.

All the specimens are in natural conditions with sawn surface finish.

APPARENT DENSITY AND OPEN POROSITY

Specimen identification number	Mass of the dry specimen (g)	Mass of the soaked specimen in water (g)	Mass of the soaked specimen in air (g)	Apparent density (kg/m ³)		Open porosity (% by volume)	
				individual values	average value	individual values	average value
1	342,65	216,00	343,23	2690		0,5	
2	340,44	214,63	340,94	2690		0,4	
3	342,9	216,16	343,51	2690		0,5	
4	342,24	215,87	342,81	2690		0,4	
5	339,86	214,27	340,32	2690		0,4	
6	342,81	216,24	343,27	2690	2690	0,4	0,4

REAL DENSITY

Specimen identification number	Mass of the pycnometer (g)	Mass of the ground and dried specimen (g)	Mass of the pycnometer + dried specimen (g)	Mass of the pycnometer + water (g)	Mass of the pycnometer + specimen + water (g)	Real density (individual values)	Real density (average value)
						(kg/m ³)	(kg/m ³)
1	45.43	24.97	70.40	145.80	161.60	2720	
2	43.78	15.15	58.93	144.98	154.55	2720	
3	43.24	24.20	67.44	144.45	159.69	2700	
4	45.30	23.22	68.52	145.65	160.29	2710	
5	43.70	26.45	70.15	145.66	162.35	2710	
6	43.91	24.58	68.49	144.46	160.00	2720	2710

TOTAL POROSITY

Apparent density (kg/m ³)	Real density (kg/m ³)	Total Porosity (% by volume)
2690	2710	0.7



WATER ABSORPTION

Test method:

The water absorption has been determined according to EN 13755 - 2003 Natural stone test methods - Determination of water absorption at atmospheric pressure.

All the specimens are in natural conditions with sawn surface finish.

Specimens: 6 cubes having 50 mm edge.

Specimen identification number	Mass of the dry specimen (g)	Mass of the saturated specimen in water (g)	Water absorption (% by mass)	
			individual values	average value
1	342,54	343,23	0,20	
2	340,36	340,88	0,15	
3	342,81	343,51	0,20	
4	342,12	342,78	0,19	
5	339,76	340,30	0,16	
6	342,72	343,26	0,16	0,2



FLEXURAL STRENGTH UNDER CONCENTRATED LOAD ON SPECIMENS BOTH IN NATURAL CONDITIONS AND SUBJECTED TO FROST TEST

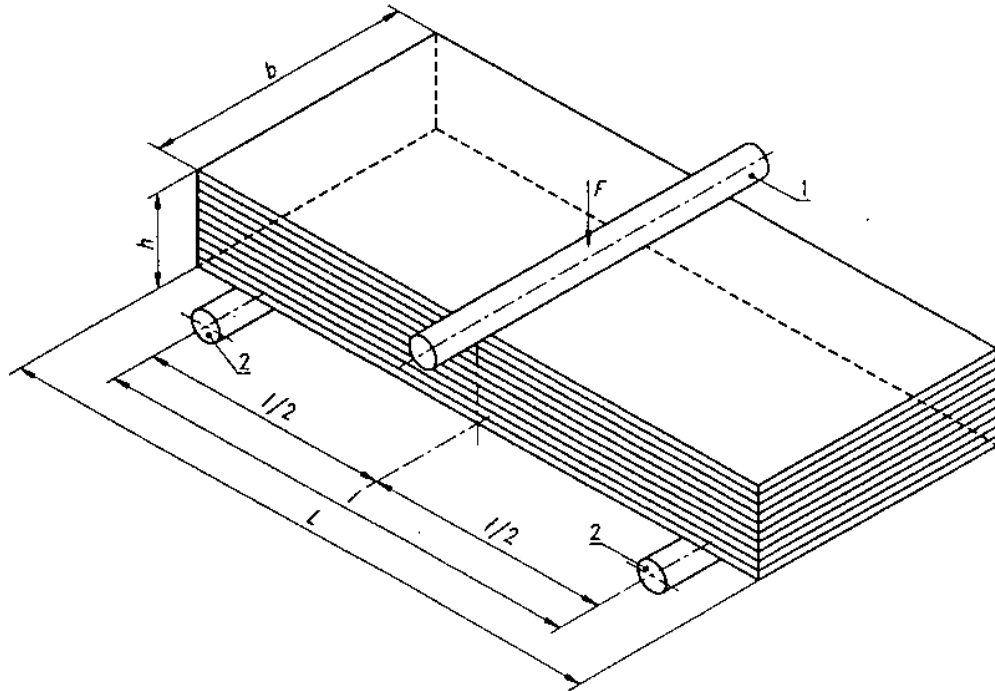

Test method:

The flexural strength has been determined according to EN 12372 - 2006 Natural stone test methods - Determination of flexural strength under concentrated load.

For the frost test ten specimens, previously saturated in water, have been submitted to 48 freezing and thawing cycles according to EN 12371 - 2001 Natural stone test methods - Determination of frost resistance.

All the specimens are in natural conditions with sawn surface finish.



Specimens in natural conditions

Specimen identification number	Length of span l (mm)	Height h (mm)	Width b (mm)	Total load at failure P (kN)	Flexural strength σ (MPa)	
					individual values	average value
1	125	25,5	49,8	2,47	14,3	
2	125	25,3	50,4	1,95	11,3	
3	125	25,5	50,3	2,39	13,7	
4	125	25,6	50,3	1,97	11,2	
5	125	25,6	50,4	1,54	8,7	
6	125	25,4	50,3	1,92	11,1	
7	125	25,2	50,5	2,03	11,9	
8	125	25,2	50,1	2,27	13,4	
9	125	25,6	50,2	1,62	9,2	
10	125	25,4	50,1	2,35	13,6	11,8

Specimens subjected to frost test

Specimen identification number	Length of span l (mm)	Height h (mm)	Width b (mm)	Total load at failure P (kN)	Flexural strength σ (MPa)	
					individual values	average value
11	125	25,2	50,7	2,02	11,8	
12	125	25,4	50,4	1,20	6,9	
13	125	25,5	50,2	1,33	7,6	
14	125	25,7	50,6	2,41	13,5	
15	125	25,8	50,6	2,22	12,4	
16	125	25,6	50,5	1,30	7,4	
17	125	25,4	50,5	1,30	7,5	
18	125	25,2	50,0	1,68	9,9	
19	125	25,4	50,7	1,81	10,4	
20	125	25,6	50,3	1,75	10,0	9,7



COMPRESSION STRENGTH ON SPECIMENS BOTH IN NATURAL CONDITIONS AND SUBJECTED TO FROST TEST

Test method:

The compression strength has been determined according to EN 1926 – 2006 Natural stone test methods - Determination of compressive strength.

For the frost test: five specimens, previously saturated in water, have been submitted to 25 freezing and thawing cycles according to EN 12371 -2001 Natural stone test methods - Determination of frost resistance.

Specimens in natural conditions

Specimen identification number	Area of the bearing surface (mm ²)	Total load at failure (kN)	Compressive strength	
			individual values (MPa)	average value (MPa)
1	5134	906	177	
2	5134	806	157	
3	5134	883	172	
4	5127	928	181	
5	5141	877	171	171

Specimens subjected to frost test

1	5141	702	137	
2	5141	656	128	
3	5127	684	133	
4	5148	773	150	
5	5134	852	166	143



DETERMINATION OF RUPTURE ENERGY

Test method:

The test has been performed according to according to EN 14158 - 2004 Natural stone test methods - Determination of rupture energy.

All the specimens are in natural conditions with sawn surface finish.

Specimen identification number	Height of fall of the steel ball at the moment of rupture of the specimen		Rupture Energy	
	individual values (cm)	average value (cm)	individual values (J)	average value (J)
1	25		2.5	
2	25		2.5	
3	25		2.5	
4	20	24	2.0	2.4



DETERMINATION OF ABRASION RESISTANCE

Test method:

The abrasion resistance has been determined according to EN 1341 -2001 Slabs of natural stone for external paving – Requirements and test methods - Annex C and EN 1342 - 2001 Setts of natural stone for external paving – Requirements and test methods - Annex B and to EN 14157 - 2004 Natural stone test methods - Determination of abrasion resistance.

All the specimens are in natural conditions with sawn surface finish.

Specimen identification number	Groove length (mm)	Mean groove length (mm)
1	17,0	17,5
2	17,5	
3	17,5	
4	18,0	
5	16,5	
6	17,0	



DETERMINATION OF SLIP RESISTANCE VALUE BY MEANS OF THE PENDULUM TESTER

Test method:

The slip resistance value (SRV) on dry specimens has been determined according to EN 14231- 2003 Natural stone test methods - Determination of the slip resistance by means of the pendulum tester.

The slip resistance value measured on wet specimens has been determined following EN 1341: 2001 “Slabs of natural stone for external paving – Requirements and test methods” Annex D, EN 1342: 2001 “Setts of natural stone for external paving – Requirements and test methods” Annex C and EN 14231- 2003 Natural stone test methods - Determination of the slip resistance by means of the pendulum tester.

For this reason for CE marking, concerning the specimens in wet conditions, the USRV (unpolished slip resistance value) requested by EN 1341 and 1342 is the same value of the SRV requested by EN 12057 and 12058.

Specimen surface: BUSH HAMMERED

Specimen identification number	SRV specimens in dry conditions	Mean SRV dry conditions	SRV - USRV specimens in wet conditions	Mean USRV wet conditions
1	81		75	
2	83		80	
3	76		72	
4	85		77	
5	75		77	
6	76	79	77	76

Specimen surface: FLAMED

Specimen identification number	SRV specimens in dry conditions	Mean SRV dry conditions	SRV - USRV specimens in wet conditions	Mean USRV wet conditions
1	78		70	
2	71		67	
3	79		68	
4	73		65	
5	71		64	
6	77	75	65	67



MODULUS OF ELASTICITY

Test method:

The moduli of elasticity have been determined according to EN 14580 - 2005 Natural stone test methods - Determination of static elastic modulus

Specimen identification number	Static elastic modulus (MPa)	Mean value (MPa)
1	80005	
2	74940	77495



DETERMINATION OF KNOOP MICROHARDNESS

Test method

The test has been performed according to EN 14205 - 2003 Natural stone test methods - Determination of Knoop hardness.

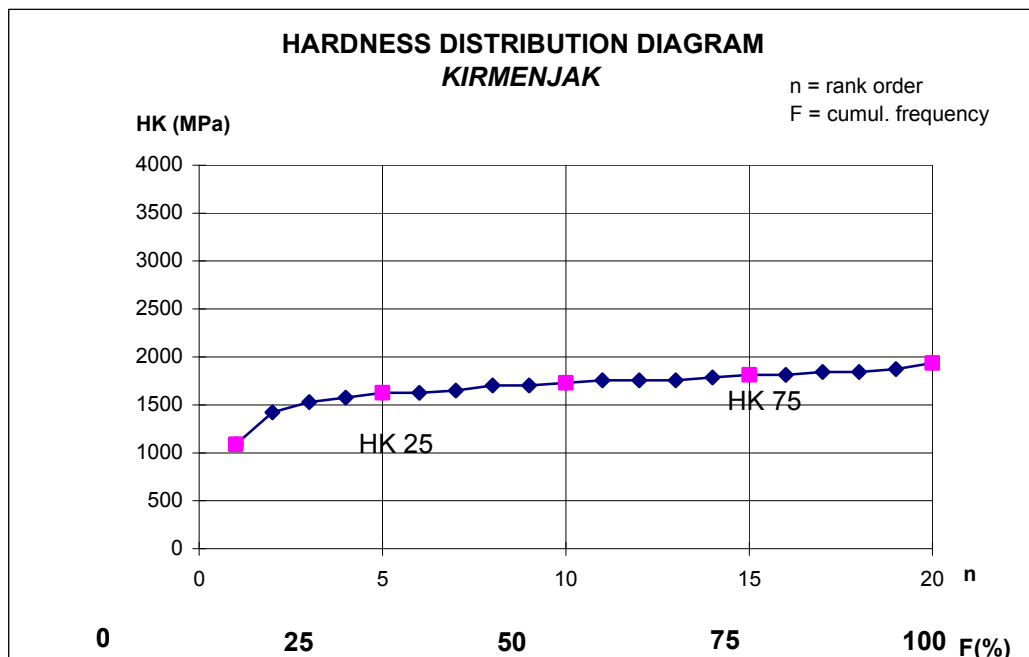

Mean value HK =	1692 MPa	HK 25 =	1625 MPa
Max value HK =	1937 MPa	HK50 =	1729 MPa
Min value HK =	1089 MPa	HK75 =	1814 MPa

Uniformity index (HK75/HK25) = 1,1



DETERMINATION OF LINEAR THERMAL EXPANSION COEFFICIENT

Test method

The test has been performed according to EN 14581 – 2004 Natural stone test methods - Determination of linear thermal expansion coefficient

Specimen identification number	Linear expansion coefficient ($10^{-6} \cdot ^\circ\text{C}^{-1}$) after the first heating cycle	Linear expansion coefficient ($10^{-6} \cdot ^\circ\text{C}^{-1}$) after the second heating cycle
1	3	4
2	3	4
Mean values	3	4

DETERMINATION OF THE BREAKING LOAD AT DOWEL-HOLE

Test method

The test has been performed according to the EN 13364 - 2001 Natural stone test methods - Determination of the breaking load at dowel hole.

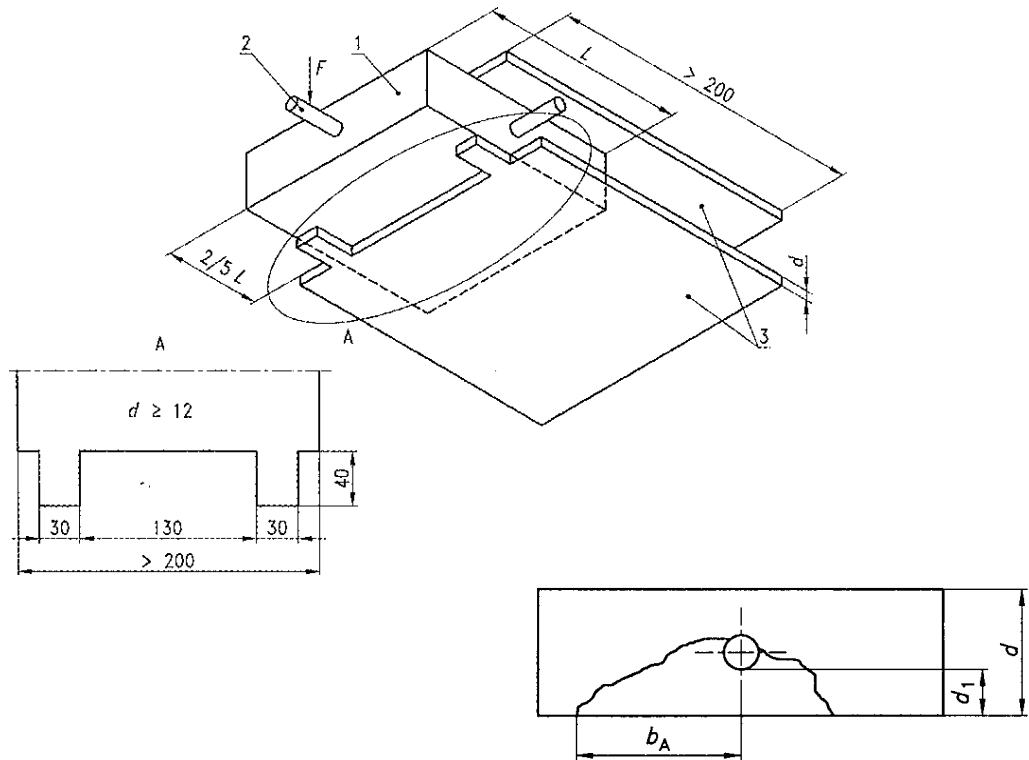

Dimensions in millimetres

Specimen identification number	Hole identification number	Specimen thickness (mm)	Breaking load (N)	Maximum distance from the centre of the hole to the edge of the fracture (b_A)(mm)	Distance from the hole to the face in the direction of the force (d_1)(mm)
1	1	30.5	1950	55	8
	2	30.5	1100	25	10
	3	30.5	2000	40	10
	4	30.5	1950	50	8
Mean values			1750	43	9



DETERMINATION OF RESISTANCE TO SALT CRYSTALLISATION

Test method:

The test has been performed according to EN 12370 - 1999 Natural stone test methods - Determination of resistance to salt crystallisation.

Specimen identification number	Initial mass of the dry specimen (g)	Initial mass of the dry specimen re-weighed with label (g)	Final mass of the dry specimen weighed with label (g)	Relative mass difference (%)
1	171.03	171.89	171.73	-0.09
2	170.97	172.12	171.94	-0.11
3	171.56	172.76	172.55	-0.12
4	171.16	172.42	172.23	-0.11
5	171.12	172.31	172.08	-0.13
6	170.67	172.02	171.83	-0.11
Average value				-0.11

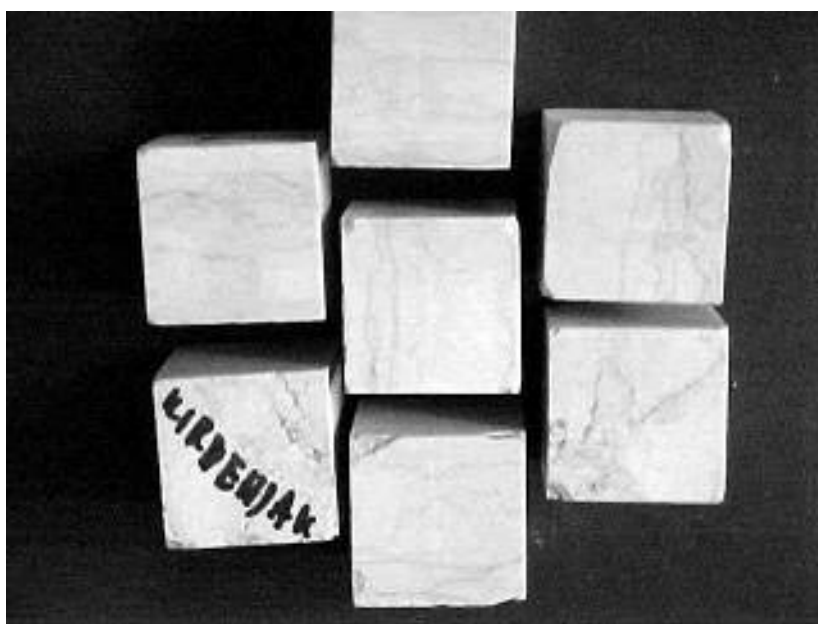

Photograph of the specimens after the crystallization test: the reference specimen is in the centre.

The test has produced slight alterations with minor detachments at the corners.



SUMMARY OF THE RESULTS
(average values)

Petrographic name:.....	limestone (fossiliferous micrite)
Apparent density:.....	2690 kg/m ³
Open porosity	0.4 % by volume
Real density	2710 kg/m ³
Total porosity:	0.7 % by volume
Water absorption	0.2 % by mass
Flexural strength in natural conditions	11.8 MPa
Flexural strength after frost test.....	9.7 MPa
Compression strength in natural conditions	171 MPa
Compression strength after frost test	143 MPa
Rupture energy: (height of fall)	24 cm
Abrasion resistance (groove length).....	17.5 (mm)
Slip resistance value - bush hammered (dry).....	79 (SRV)
Slip resistance value - bush hammered (wet)	76 (SRV -USRV)
Slip resistance value - flamed (dry).....	75 (SRV)
Slip resistance value - flamed (wet)	67 (SRV - USRV)
Static modulus of elasticity	77495 MPa
Knoop microhardness (HK 25).....	1625 MPa
Knoop microhardness (HK 75).....	1814 MPa
Linear expansion coefficient	$3-4 * 10^{-6} * ^\circ C^{-1}$
Breaking load at dowel-hole.....	1750 N
Breaking load at dowel-hole, maximum fracture distance	43 mm
Resistance to salt crystallisation	- 0.11 % (mass difference)